

## 5021-S SPRING APPLIED BRAKE CALIPER

The purpose of a spring applied caliper is to provide a braking device that will apply upon failure of fluid pressure. When the fluid pressure is removed from the spring applied actuator the springs will apply the brake. An option with a manual release screw is available for releasing the brake in the absence of the fluid pressure. To achieve various clamping forces, several different springs are available.

The actuators are all made of bronze and stainless steel hardware, together with carbon steel springs. Upon special request, stainless springs are available. The maximum fluid pressure in the actuator should not exceed 250 psi.

### Specifications

Clamping force	9160 lbf	(40.7 kN)
Max. disc thickness	2 in.	(51 mm)
Req. disc face	4 in.	(102 mm)
Total lining area	60 sq. in.	(387 sq. cm)
Lining thickness	0.5 in.	(12.7 mm)
Max. allowable lining wear	0.30 in.	(7.6 mm)
Average wear rate	0.005 cu. in./HP-hr	(0.082 cu. cm/HP-hr)
Coefficient of friction	0.45 – 0.5	at 20° - 260°C
Max. release pressure	120 psi	(8.3 bar)
Max. pressure	250 psi	(17 bar)
Actuator volume	19 cu. in.	(311 cu. cm)
Weight	59 lb.	(26.3 kg)
Materials	Die cast silicon bronze with stainless steel hardware	

### Ordering Information

5021-S	Spring Applied Brake Caliper
5021-SR	Spring Applied Brake Caliper with manual release screw

When ordering brake calipers for discs smaller than the standard thickness, shim kits are available for adjustment. Add the last four digits of the appropriate kit to the code when ordering.

Example: 5021-S1250 is for a 5021-S brake caliper set for 1¼" thick disc.

A variety of custom made disc are available. For discs smaller than the standard thickness, refer to the shim kit table below.

### STANDARD VENTILATED KOBELT DISC: 2 in. (51mm)

Disc Dia.	18	20	25	30	35	40	45	50
inches	18	20	25	30	35	40	45	50
mm	457	508	635	762	889	1016	1143	1270
Acting Rad.								
ft	0.58	0.67	0.88	1.08	1.29	1.50	1.71	1.92
meter	0.18	0.20	0.27	0.33	0.39	0.46	0.52	0.58
Torque ‡								
ft-lb	2227	2563	3402	4242	5082	5921	6760	7600
kg-m	308	354	470	586	703	819	935	1051
Maximum RPM	3070	2750	2200	1800	1550	1350	1200	1070

‡ Brake torques are theoretical values only

Disc thickness	Shim Kit Part number	Total shim size
1.50 in. (38.1 mm)	5021-1500	0.50 in (12.7 mm) 1 shim (1/4") per side
1.25 in. (31.8 mm)	5021-1250	0.75 in (19 mm) 1 shim (3/8") per side
1.00 in. (25.4 mm)	5021-1000	1.00 in. (25.4 mm) 2 shims (1/4") per side
0.75 in. (19 mm)	5021-0750	1.25 in. (31.8 mm) 2 shims (3/8"+1/4") per side
0.50 in. (12.7 mm)	5021-0500	1.50 in. (38.1 mm) 2 shims (3/8") per side

# MODEL 5021-S

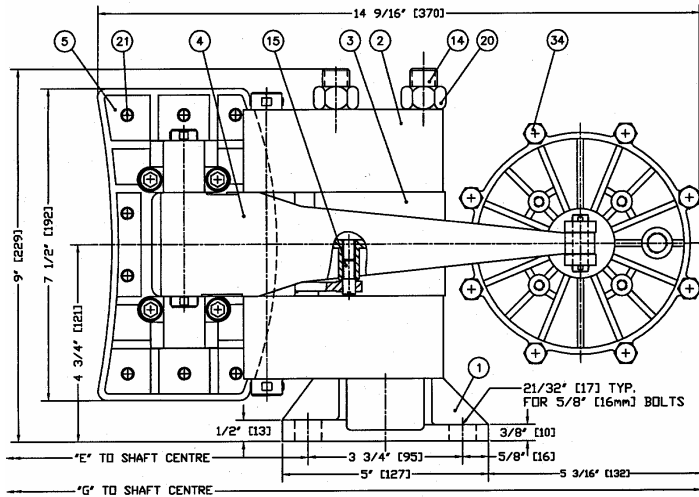

Note: Springs are made of carbon steel

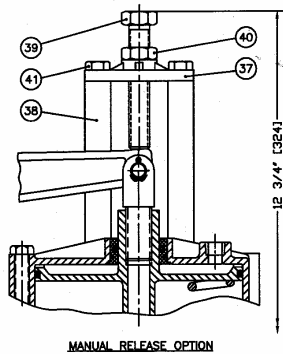
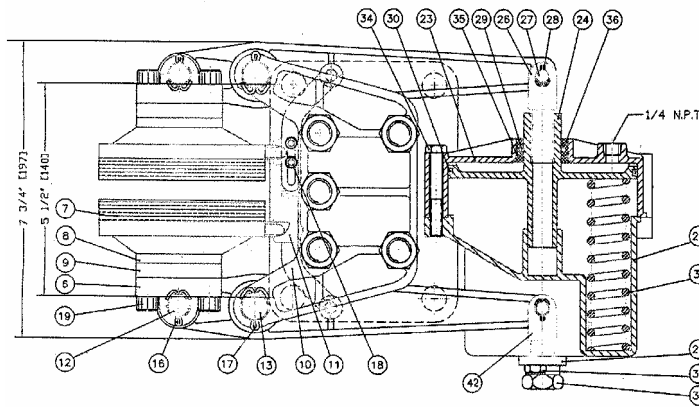

MANUAL RELEASE OPTION

All dimensions in inches (mm)

Disc diam inches mm	18 457	20 508	25 635	30 762	35 889	40 1016	45 1143	50 1270
Dim. "E" inches mm	9.63 245	10.63 270	13.13 334	15.63 397	18.13 461	20.63 524	23.13 588	25.63 651
Dim. "G" inches mm	19.4 492	20.4 518	22.9 581	25.4 645	27.9 708	30.4 772	32.9 835	35.4 899

Item	Qty	Part No.	Description
1	1	5021-0001	Foot
2	2	5021-0002	Saddle
3	1	5021-0003	Spacer
4	2	5021-0004	Lever
5	2	5021-0005	Shoe
6	4	5021-0006	Hinge Block
7	2	5021-0007	Lining
8	*	5021-0008	1/4" Shim
9	*	5021-0009	3/8" Shim
10	2	5021-0011	Balancing Link No. 1
11	2	5021-0012	Balancing Link No. 2
12	2	5021-0021	Shoe Pin
13	2	5021-0022	Saddle Pin
14	5	5021-0023	Tie Rod
15	2	5021-0226	Link Pin
16	4	1026-0516	Cotter Pin
17	4	1026-0824	Cotter Pin
18	4	1002-0808	Socket Hd Screw
19	8	1002-1216	Socket Hd Screw (standard)
19	*	1002-1220	Socket Hd Screw (5021-1500)
19	*	1002-1224	Socket Hd Screw (5021-1250/1000)
19	*	1002-1228	Socket Hd Screw (5021-0750/0500)
20	5	1022-0116	Nut
21	24	1033-1007	Rivet

### 6212 Spring Applied Pot

22	1	6212-0001	Spring Housing
23	1	6212-0002	Piston Housing
24	1	6212-0003	Piston
25	1	6212-0004	Bracket
26	1	6212-0005S	Clevis, short
27	2	6112-0010-L	Pin
28	4	1026-0312	Cotter Pin
29	1	1101-0214	"O" Ring
30	1	1101-0248	"O" Ring
31	8	1201-0035	Spring
32	1	1022-0216	Jam Nut
33	2	1001-1112	Hex Hd Bolt
34	8	1001-1136	Hex Hd Bolt
35	1	1101-0026	"O" Ring
36	1	6212-PHB	Bushing
42	1	6212-0005L	Clevis, long

### Manual Release Option

37	1	6212-0006	Manual Release Bracket
38	4	6212-0007	Spacer
39	1	1001-1448	Release Screw
40	1	1022-0214	Jam Nut
41	4	1001-1156	Hex Hd. Bolt

\* Quantity may vary with options

**Caution:** When dismantling the actuator, it is important that it is retained in a press before the holding screws are removed.